

LED Premium Flood Light – 100W

Model: RL-ULFLC100W



LED flood lights are suitable for both outdoor and indoor commercial applications such as parking areas, billboards and common areas

Product Features

- Super slim and efficient design
- Aluminium die cast housing
- Tempered glass face
- Long operating life and performance
- 120° Beam Angle
- IP65 Waterproof housing

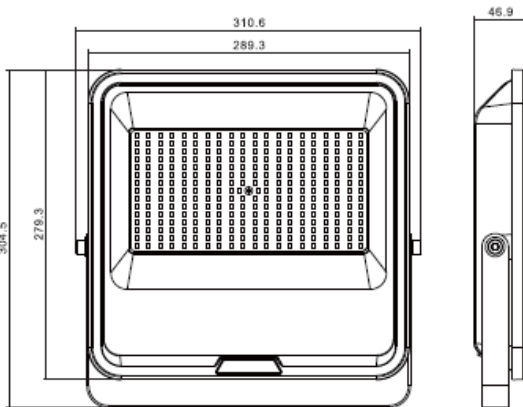

100W

SPECIFICATION

Colour	Cool White (5500K)
Lumen (lm)	15000lm
Efficiency (Lm/w)	>150lm/w
Light Source	SMD 2835
CRI (%)	≥70 or ≥80
Beam Angle	120°
Power Requirement	AC100-2770V ~ 50/60Hz
Power Consumption	100W
Housing	Die Cast Aluminium and Tempered Glass
Lifespan	> 40,000 hours
Operation Temperature	-20°C~+40°C
Dimension (mm)	305(L) x311(W) x47(D)
IK Rating	IK08
Protection Rating	IP65
Warranty	5 years