

LED Slimline Flood Light – 100W

With Built in Sensor - Optional Use - By Remote

Model: RLFL100W

LED flood lights are suitable for both outdoor and indoor commercial applications such as parking areas, billboards and common areas.



Product Features

- Built In Sensor
- Aluminium die cast housing
- Tempered glass face
- Long operating life and performance
- 120° Beam Angle
- IP66 Waterproof housing

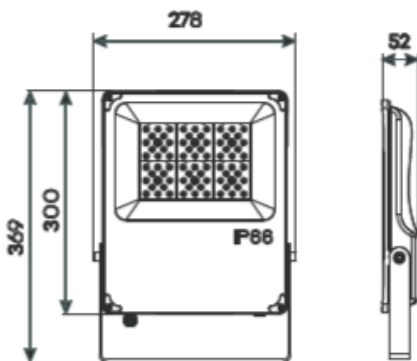

SPECIFICATION	
Colour	Cool White (5500K)
Lumen (lm)	14000lm
Efficiency (Lm/w)	>140lm/w
Light Source	Lumileds 3030
CRI (%)	>80%
Beam Angle	120°
Power Requirement	AC 100~240V
Power Consumption	100W
Housing	Die Cast Aluminium and Tempered Glass
Lifespan	> 40,000 hours
Operation Temperature	-20°C~+40°C
Dimension (mm)	369 × 278 × 52
Sensor (option)	Daylight & Microwave Motion Sensor
Protection Rating	IP66
Warranty	5 years